

# TOX®-ElectricDrive Core

System and Components  
Typenblatt 40.15

2023 / 03

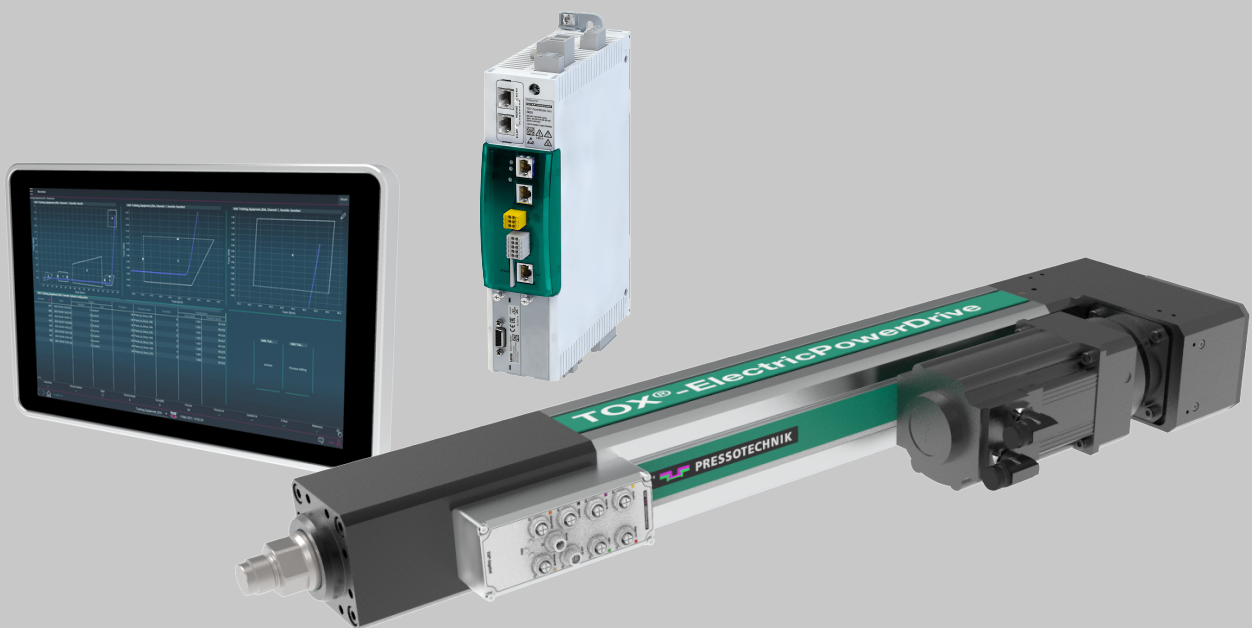

Subject to technical changes.

# TOX® ElectricDrive Core

## System setup

The scope of delivery is composed of the following components:

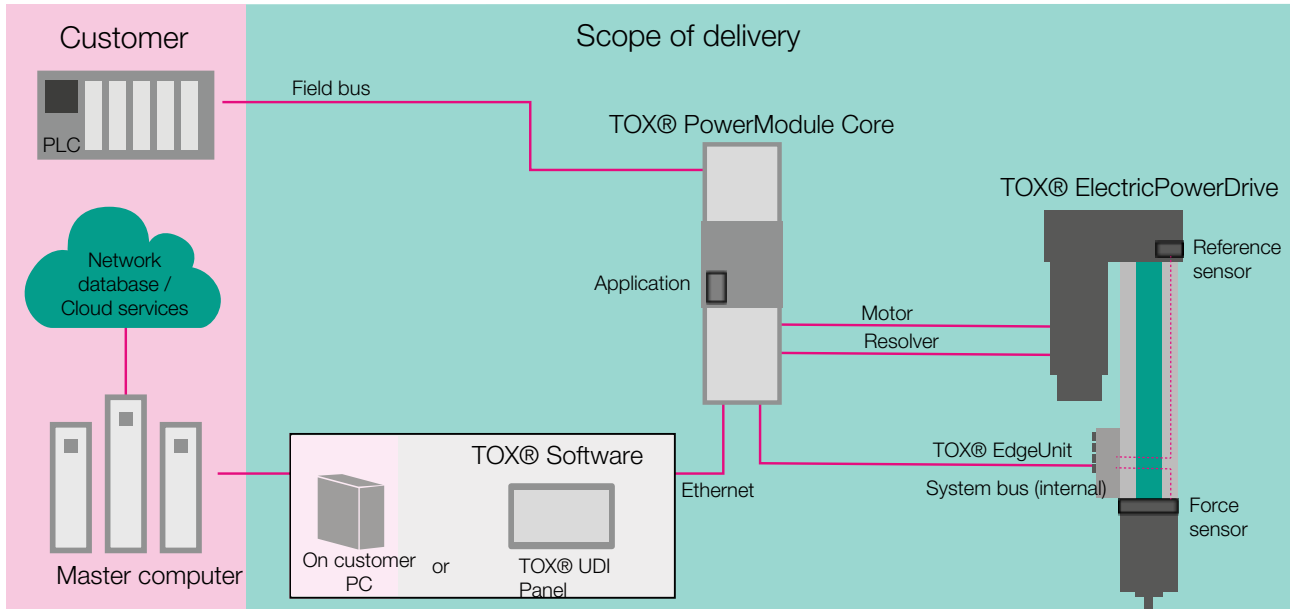

## Block diagram

The block diagram displays the system schematically.

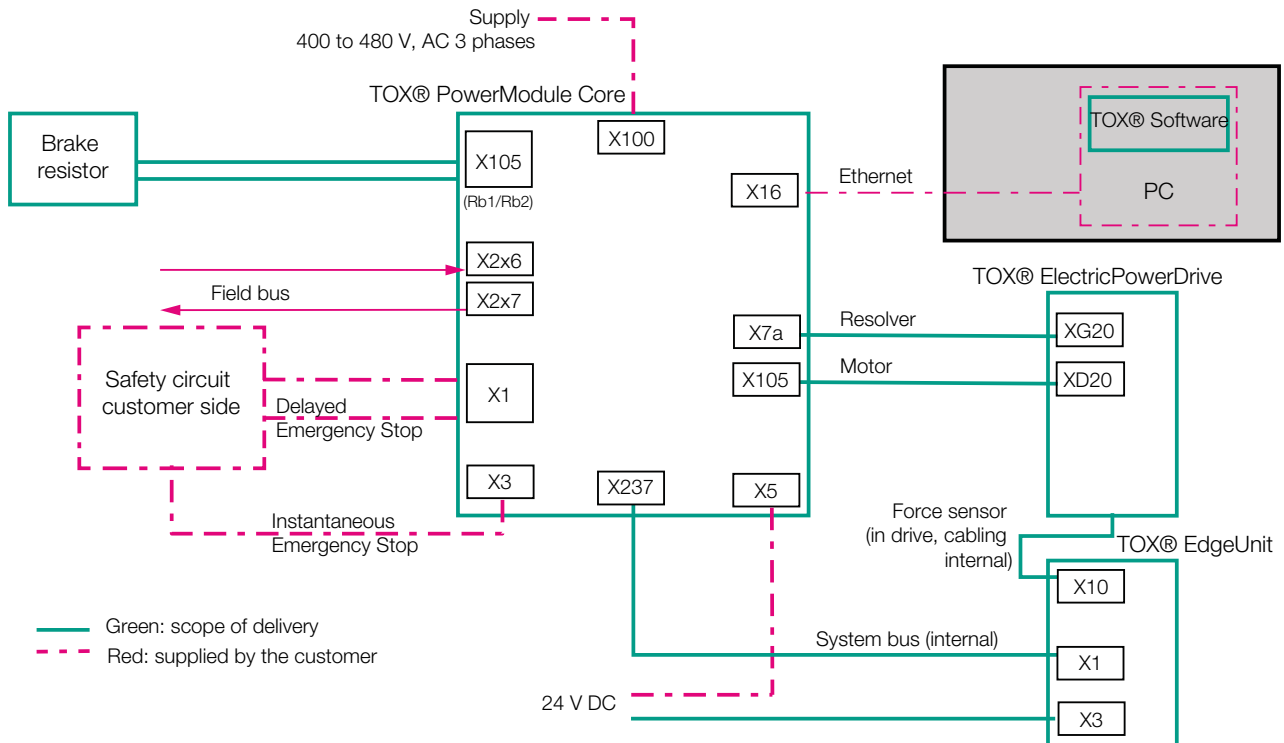

# TOX® ElectricDrive Core

## TOX® ElectricPowerDrive

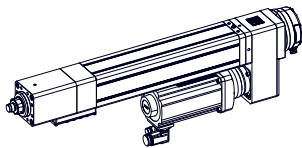
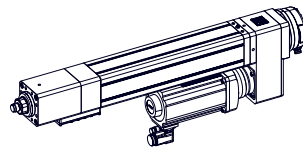
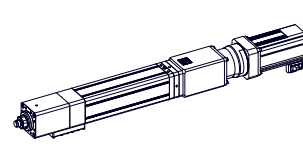
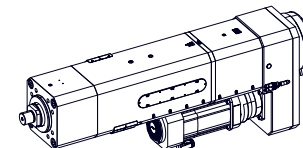
Type EQe-K	Type EXe-K	Type EXe-F	Type EXe-L
			
Cost-efficient solution	Flexible for any solution	For high speed solutions	High press forces
Ball screw	Planetary roller screw	Planetary roller screw	Planetary roller screw
<ul style="list-style-type: none"> <li>Nominal force: 2 kN, 5 kN, 10 kN, 30 kN, 60 kN, 100 kN</li> <li>Press force range: 0.02 kN - 100 kN</li> <li>Stroke length: 150 mm, 300 mm, 450 mm</li> </ul>	<ul style="list-style-type: none"> <li>Nominal force: 10 kN, 30 kN, 60 kN, 100 kN, 200 kN</li> <li>Press force range: 0.1 kN - 200 kN</li> <li>Standard stroke length: 150 mm, 300 mm, 450 mm</li> <li>High power density with small space requirement and low weight</li> </ul>	<ul style="list-style-type: none"> <li>Nominal force: 5 kN, 10 kN, 30 kN, 60 kN, 100 kN</li> <li>Press force range: 0.05 kN - 100 kN</li> <li>Standard stroke length: 150 mm, 300 mm</li> <li>Stroke speed: up to 800 mm/s</li> </ul>	<ul style="list-style-type: none"> <li>Nominal force: 300 kN, 400 kN, 500 kN, 700 kN, 1,000 kN</li> <li>Press force range: 3 kN - 1,000 kN</li> <li>Standard stroke length: 300 mm</li> <li>Alternative to hydraulics</li> </ul>
	Customer-specific versions are possible	Customer-specific versions are possible	Customer-specific versions are possible
For further information see data sheet 40.45	For further information see data sheet 40.55	For further information see data sheet 40.65	For further information see data sheet 40.25

For data sheets see [www.tox-pressotechnik.com](http://www.tox-pressotechnik.com)

## TOX® EdgeUnit

The TOX® EdgeUnit works like a decentralized intelligence. It collects data at the place where they are recorded, and sends the bundled data digitally to the TOX® PowerModule Core.

### General technical data

- Ambient temperature: 0 - 50°C
- IP protection: IP 65 (connector closed)
- Housing: aluminum
- The status LED shows different statuses of the TOX® EdgeUnit
- Integrated memory

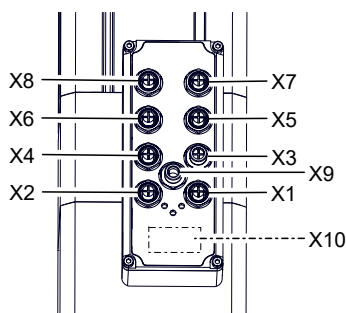

Designation	Interfaces
<b>X1</b>	EtherCAT IN, including status LED
	Connection type: M12 4-pin bushing, D-coded
<b>X2</b>	EtherCAT OUT, including status LED
	Connection type: M12 4-pin bushing, D-coded
<b>X3</b>	Supply voltage
	Voltage: + 24 V DC (18 - 28 V DC)
	Current consumption: < 0.25 A (without outputs to X7)
	US1 and US2: Supply power/actuator power
	Connection type: M12 5-pin, connector A-coded
<b>X4</b>	Digital IN
	Digital IN 1 / Digital IN 2: 24 V DC
	Logic level 0 (LOW): 0 V - 10 V
	Logic level 1 (HIGH): 16 V - 28 V
	Input current: max. 2 mA (at 24 V)
	Connection type: M12 5-pin bushing, A-coded

# TOX<sup>®</sup> ElectricDrive Core

Designation	Interfaces
<b>X5</b>	Strain gauge 2
measuring range	1.157 mV/V to 3.25 mV/V (adjustable gain)
Voltage VDC	5 V
Bridge resistance	700Ω
Resolution	16 bit
Connection type	M12 5-pin bushing, A-coded
<b>X6</b>	Analog IN
Analog IN 1	-10 - 10 V DC, 16 bit
Analog IN 2	0 - 10 V DC, 12 bit
Connection type	M12 5-pin bushing, A-coded

Designation	Interfaces
<b>X7</b>	Digital OUT
Digital OUT 0 / Digital OUT 1	24 V DC, US2
Output current	max. 2 A (per channel) / excess current and short-circuit safe
Connection type	M12 5-pin bushing, A-coded
<b>X8</b>	Encoder
Connection type	M12 8-pin bushing, A-coded
<b>X9</b>	Service plug
Connection type	M12 8-pin connector, A-coded

## TOX<sup>®</sup> PowerModule Core

The TOX<sup>®</sup> PowerModule Core is required for operating the drive as well as for parameterization and visualization.

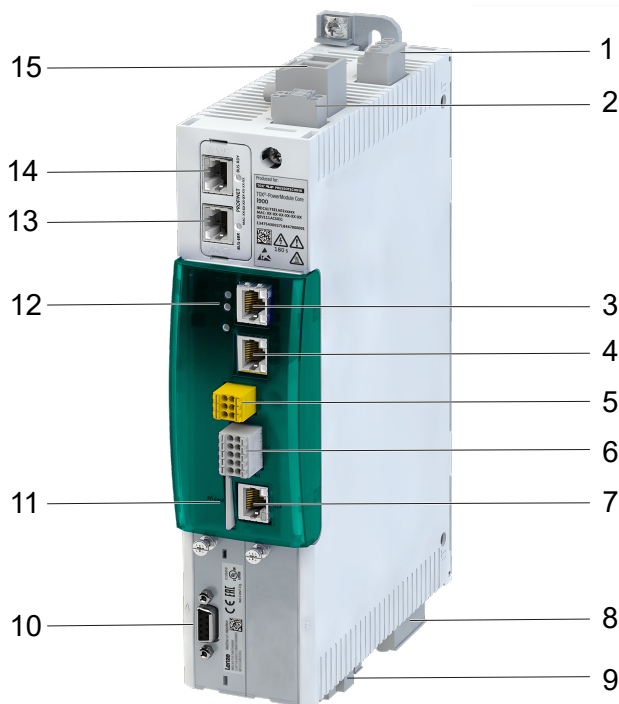

### Properties

- Fast commissioning (plug & play)
  - Open parameterization, comprehensive programming and diagnostic functions
  - Definition of process jumps, i.e. with flexible response to abort events, functions can be skipped.
  - Configuration of multiple conditions
  - Configuration, definition and querying of variables
  - 500 processes and 8000 functions
- Mathematical and calculation functions are available
- Switching to external force sensors and/or external linear position sensor during travel is possible
  - Hold force, regulate force
  - Predefined sample processes
  - Window and envelope monitoring
  - Freely definable rework/recovery
  - Definable transition speed from one movement function to the next

The server controller is available as extended safety version as an option.

No	Designation	Description
1	Power supply connection	Power supply
2	24 V supply of control electronics	Connection for the control electronics
3	System bus (internal) IN	EtherCAT input (internal communication)
4	System bus (internal) OUT	EtherCAT output (internal communication)



# TOX® ElectricDrive Core

No	Designation	Description
5	Basic Safety-STO	<p>The integrated safety technology offers the control and drive prerequisites for the implementation of protective functions.</p> <ul style="list-style-type: none"> <li>■ Safe shutdown of the energy supply for the servo controller output stage (STO) in PLc. This safety function prevents accidental system startup.</li> <li>■ optional extended safety: (PROFISafe, FSoE, SLS, SOS)</li> <li>■ Further safety functions available on request.</li> </ul>
6	Control clamp	<p>I/O periphery</p> <ul style="list-style-type: none"> <li>■ Power <ul style="list-style-type: none"> <li>– 24 VDC Supply</li> </ul> </li> <li>■ Digital IN <ul style="list-style-type: none"> <li>– DI1 Safety brake feedback (closed = logic level 1)</li> <li>– DI2 Reset error</li> <li>– DI3 Brake resistor temperature (temp ok = logic level 1)</li> <li>– DI4 Program abort</li> </ul> </li> <li>■ Digital OUT <ul style="list-style-type: none"> <li>– DO1 STO status (safety ok = logic level 0)</li> </ul> </li> </ul>
7	Ethernet	<p>Connection to the TOX® Software</p> <ul style="list-style-type: none"> <li>■ Connection to TOX® UDI Panel, or Line IPC (customer), where the TOX® Software can be installed.</li> <li>■ The TOX® Software must be used for initial parameterization. During production a higher control system (customer PLC / robot) can be used as alternative for driving, or process data adjustment for example.</li> <li>■ The TOX® Software is used to store the quality data on an IPC or a freely definable location, or can be passed through. Process backups are/can be created automatically.</li> </ul>
8	Connection of motor and brake resistor	<p>Connection for motor and brake resistor. The brake resistor is a load resistor.</p> <ul style="list-style-type: none"> <li>■ It transforms excess motor brake energy to heat. The resistor is installed on the control cabinet by default since it generally does not get hot during standard processes (internal brake resistor).</li> <li>■ The brake resistor can optionally also be installed outside of the control cabinet for improved heat dissipation (external brake resistor).</li> <li>■ For the larger drives, only an external brake resistor is provided due to the high heat development.</li> </ul>
9	Connection of motor holding brake	<p>For optional equipment: connection for the motor holding brake and brake voltage from a separate mains adapter.</p>
10	Resolver	<p>Phase angle determines the motor position.</p>
11	Memory card	<p>Contains the entire TOX® know-how</p> <ul style="list-style-type: none"> <li>■ Application and process sequence</li> <li>■ The process sequence can be programmed by the customer.</li> </ul>
12	Status of LED converter	
13	Connection of fieldbus (either Profinet, EtherNetIP or EtheCAT) (*)	<ul style="list-style-type: none"> <li>■ Interface to the PLC /to the robot</li> <li>■ Program selection, signal exchange, start</li> <li>■ Move to PLC values as well as program numbers and parameters, such as force and speed for example.</li> <li>■ Data scope can be defined application-specific: 32 words (switch-over possible)</li> <li>■ Final values, actual values (force/position/window results)</li> <li>■ Part serial information from the PLC to the servo controller (96 digit ASCII string)</li> </ul>
14		
15	DC bus	<p>Optional possibilities of connection for intermediate circuit.</p>

# TOX® ElectricDrive Core

## (\* Flexible fieldbus interface



The interface can be freely designed:

- Independent of hardware
- No prioritized function modules for PLC manufacturers necessary
- Data scope can be defined application-specific: 32 words, switch-over possible
- FIXED TABLE, 10 words
- SWITCHING TABLE, max. 16 x 22 words (e.g. PLC values, final values of window results, part information, freely configurable pages, )
- Move to PLC standard values independent of PLC type

## Overview of sizes TOX® PowerModule Core

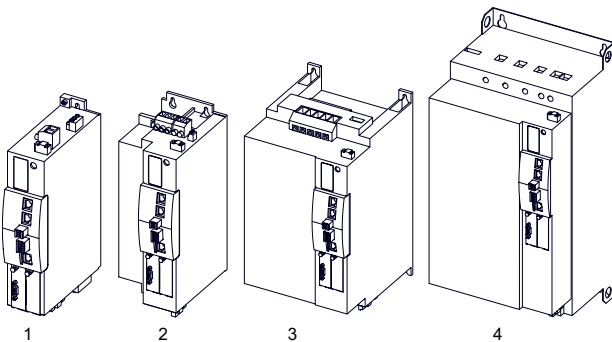

For TOX® ElectricPowerDrive	Rated power	Size	Size Dimensions (H x W x D)	Weight	Pre-fuse (not included in delivery)
EQe-K 002	2.2 kW	1	338 x 60 x 187 mm	1.6 kg	B10 A
EQe-K 005					B10 A
EQe-K 010					B10 A
EXe-F 005					B16 A
EQe-K 030	4 kW	1	338 x 60 x 187 mm	1.6 kg	B16 A
EQe-K 060					B16 A
EXe-K 010					B10 A
EXe-K 030					B16 A
EXe-F-010	7.5 kW	2	375 x 120 x 187 mm	3.9 kg	B16 A
EXe-K 060					B32 A
EXe-F 030					B32 A

# TOX® ElectricDrive Core

For TOX® ElectricPowerDrive	Rated power	Size	Size Dimensions (H x W x D)	Weight	Pre-fuse (not included in delivery)
EQe-K 100	11 kW	2	375 x 120 x 187 mm	3.9 kg	B25 A
EXe-K100	15 kW	2	375 x 120 x 187 mm	3.9 kg	B32 A
EXe-F 060					B32 A
EXe-K 200	22 kW	3	440 x 204.5 x 253 mm	10.7 kg	B40 A
EXe-F 100					B32 A
EXe-L 300					B63 A
EXe-L 400					B63 A
EXe-L 500					B63 A
EXe-L 700					B63 A
EXe-L 1000	45 kW	4	635 x 250 x 245 mm	16.7 kg	B80 A

## Brake resistor

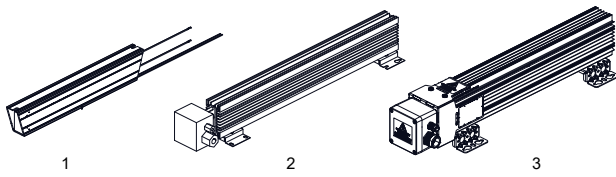

- |   |                                  |   |                                  |
|---|----------------------------------|---|----------------------------------|
| 1 | Size 1 (internal brake resistor) | 2 | Size 2 (external brake resistor) |
| 3 | Size 3 (external brake resistor) |   |                                  |

The brake resistor is a load resistor.

- It transforms excess energy to heat. The resistor is installed in the control cabinet by default (internal brake resistor).
- The brake resistor can optionally also be installed outside of the control cabinet for improved heat dissipation (external brake resistor). Additional cooling of the control cabinet might not be necessary under certain circumstances.
- For the larger drives, only an external brake resistor is provided due to the high heat development.

For TOX <sup>®</sup> ElectricPowerDrive	Resistance	Rated power	Protection class	Dimension (H x W x D)	Size
EQe-K 002	180 Ω	270 W	IP54	335 x 30 x 60 mm (internal)	1
EQe-K 005					
EQe-K 010					
EXe-F 005					
EQe-K 030	47 Ω	270 W	IP54	335 x 30 x 60 mm (internal)	1
EQe-K 060					
EXe-K 010					
EXe-K 030					
EXe-F-010					
EXe-K 060					
EXe-F 030	18 Ω	800 W	IP65	710 x 114 x 105 mm (external)	2
EQe-K 100					
EXe-K100	18 Ω	800 W	IP65	710 x 114 x 105 mm (external)	2
EXe-F 060					
EXe-K 200					
EXe-L 300					
EXe-L 400					
EXe-L 500					
EXe-L 700					
EXe-F 100					
EXe-L 1000	7.5 Ω	800 W	IP65	530 x 124 x 120.5 mm (external)	3

## Cable set



### Technical data

- Available lengths: 5, 10, 15, 20, 25 m
- Standard version: drag-chain-suitable
- Optional: robotic flex (torsional)
- Optional: halogen-free

# TOX® ElectricDrive Core

## Characteristics

<b>Connector</b> TOX® PowerModule Core-side	<ul style="list-style-type: none"> <li>■ Connecting cable from motor: flying leads</li> <li>■ Connecting cable from resolver: D-SUB connector</li> <li>■ EtherCAT connection to TOX® EdgeUnit with connector M12D and RJ45 connection to TOX® PowerModule Core.</li> </ul>
<b>Connector</b> TOX® ElectricPowerDrive-side	<ul style="list-style-type: none"> <li>■ Motor connector: Intercontec SpeedTec</li> <li>■ Resolver connector: Intercontec SpeedTec</li> <li>■ 24 V power cable: M12 5-pin connector, A-coded</li> <li>■ EtherCAT cable: M12 4-pin connector, D-coded</li> </ul>
<b>Connector</b> Mains adapter (customer side)	<ul style="list-style-type: none"> <li>■ 24 V supply to TOX® EdgeUnit with free cable end (customer side)</li> </ul>

For TOX® ElectricPower- Drive	cable	Cross-section	Number of wires	Bending radius for firm installation	Bending installation of drag-chain
EQe-K 002	Motor cable	2.5 mm <sup>2</sup>	4	min. 4 x d = 46 mm	min. 7.5 x d = 86.25 mm
EQe-K 005	Motor cable with motor holding brake	2.5 mm <sup>2</sup> + 1.5 mm <sup>2</sup>	4 + 2	min. 5 x d = 70 mm	min. 10 x d = 140 mm
EXe-F 005					
EQe-K 010					
EXe-K 010					
EXe-F 010					
EQe-K 030					
EXe-K 030					
EXe-F 030					
EQe-K 060					
EXe-K 060					
EQe-K 100	Motor cable	4 mm <sup>2</sup>	4	min. 4 x d = 54 mm	min. 7.5 x d = 101.25 mm
EXe-F 060	Motor cable with motor holding brake	4 mm <sup>2</sup> + 1.5 mm <sup>2</sup>	4 + 2	min. 5 x d = 75 mm	min. 10 x d = 150 mm
EXe-K 100					
EXe-F 100					
EXe-K 200					
EXe-L 300	Motor cable	10 mm <sup>2</sup>	4	min. 4 x d = 74 mm	min. 7.5 x d = 138.75 mm
EXe-L 400					
EXe-L 500					
EXe-L 700					
For all TOX® ElectricPower- Drive types	Resolver cable	0.25 mm <sup>2</sup>	4 x 2	min. 4 x d = 32 mm	min. 7.5 x d = 60 mm
	Power cable 24 V	1.5 mm <sup>2</sup>	5	min. 4 x d = 36.4 mm	min. 7.5 x d = 68.25 mm
	EtherCAT cable	0.34 mm <sup>2</sup>	4	min. 5 x d = 33.5 mm	min. 12 x d = 80.4 mm

## Safety equipment

### Motor holding brake and safety brake

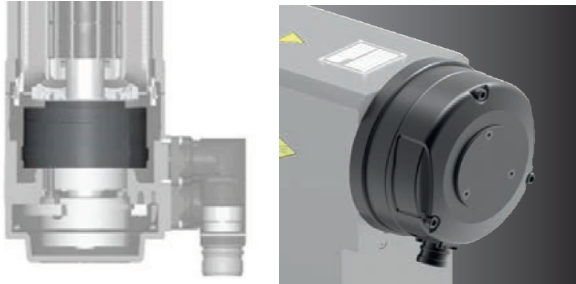

The drive systems are very effective and for this reason have a low self-retention, i.e. the tool can drop down when power is lost. The maximum permissible tool weights can be found in the technical data sheets of the TOX<sup>®</sup> ElectricPowerDrive.

Dropping can be prevented with weights in excess of these with the aid of a separate brake.

Two different types of brakes are available.

- Motor holding brake (integrated in the motor)
- Safety brake (installed on the TOX<sup>®</sup> ElectricPowerDrive)

### Motor holding brake (integrated in the motor)

When power is lost, and also with a vertical facility, the motor holding brake prevents the weight-loaded working piston from dropping. It protects the drive, the tools and the workpieces against damage. The motor holding brake is connected by means of the motor cable included in the cable set. A separate supply voltage is required on

the TOX<sup>®</sup> ElectricDrive Core for the motor holding brake. A motor holding brake is not available for the TOX<sup>®</sup> ElectricPowerDrive type EXe-L.

The motor holding brake does not function as a safety brake.

### Safety brake (installed on the TOX<sup>®</sup> ElectricPowerDrive)

The TOX<sup>®</sup> ElectricPowerDrive EQe-K, EXe-K, EXe-L can be fitted with a safety brake. During a malfunction it stops the drive and protects against injuries. The functionality of the brake is checked prior to every cycle. This conforms to the work safety regulations and standards of the trade associations.

The safety brake for the drive types EQe-K, EXe-K and EXe-L is designed as spring-loaded brake. When the power is switched off, the brake and the drive, or the dynamically loaded working piston stop.

The parameters are already preset in the brake switch module according to the size of the safety brake.

# TOX® ElectricDrive Core

## Delivery of the safety brake



Fig. 1 Safety brake, brake switch module, cable

### Scope of delivery

Safety brake	Size in dependence of the size of the TOX® ElectricPowerDrive.
Brake switch module	For TOX® ElectricPowerDrive, type EQe-K, EXe-K, EXe-L
cable	25 m long cable from the safety brake to the brake switch module. It can be connected to the safety brake and has an open cable end on the other side. The cable can, or must be, shortened during the installation.

## Performance data of safety brake

Drive	Brake	Rated voltage	Rated power	Brake switch module Dimension (H x W x D)
EQe-K 002	RSM 2	16 V*	16 W	100 x 45 x 120 mm
EQe-K 005	RSM 2	16 V*	16 W	
EQe-K 010	RSM 8	16 V*	30.5 W	100 x 45 x 120 mm
EQe-K 030	RSM 16	16 V	24 W	
EQe-K 060	RSM 32	16 V*	51 W	100 x 45 x 120 mm
EQe-K 100	RSM 60	16 V*	66 W	
EXe-K 010	RSM 2	16 V*	16 W	100 x 45 x 120 mm
EXe-K 030	RSM 8	16 V*	30.5 W	
EXe-K 060	RSM 16	16 V*	42 W	100 x 45 x 120 mm
EXe-K 100	RSM 32	16 V*	51 W	
EXe-K 200	RSM 60	16 V*	66 W	100 x 45 x 120 mm
EXe-L 300	RSM 250	24 V	116 W	
EXe-L 400	RSM 250	24 V	116 W	100 x 45 x 120 mm
EXe-L 500	RSM 500	24 V	143 W	
EXe-L 700	RSM 500	24 V	143 W	100 x 45 x 120 mm
EXe-L 1000	RSM 500	24 V	143 W	

(\*) internal voltage drop in the brake switch module.

The TOX<sup>®</sup> Software is necessary for the parameterization of the system.

It includes all required functions for fast and simple configuration, parameterization, visualization and diagnosis of the servo drive systems.

View: integrated archive



View: freely designable dashboard, landscape format

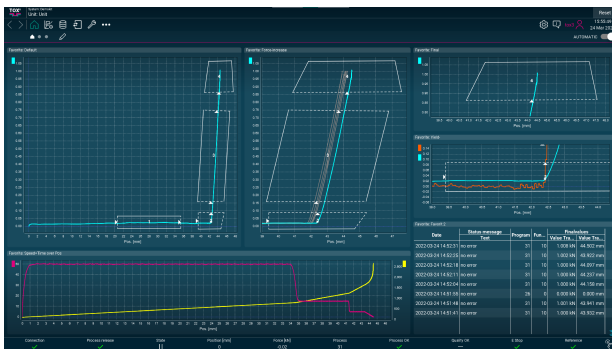

View: freely designable dashboard, portrait format

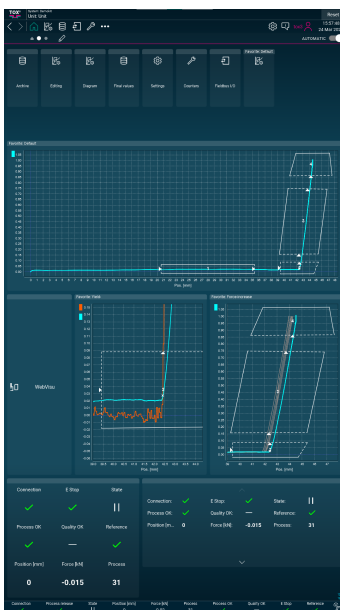

Properties:

- Flexible screen layout (dashboard)
- Intuitive operation
- Network based (Ethernet TCP/IP)
- Multiple login levels for user management and security
- Powerful functions
- Adjustable to customer-specific requirements
- Data backup, data export of quality data (xml, csv, json, pdf)
- Multilingual
- In-house engineering

## System Requirements

The requirements for the customer PC depend on the number of TOX<sup>®</sup> ElectricDrive Core systems and function parameters/conditions.

Supported operating systems:

- Microsoft<sup>®</sup> Windows 10<sup>®</sup> and higher
- Ubuntu MATE 22.04 LTS and higher

Up to 3 TOX<sup>®</sup> ElectricDrive Core systems:

- min. i3, 7th Generation
- 8 GB Ram
- 120 GB SSD

Up to 10 TOX<sup>®</sup> ElectricDrive Core systems:

- min. i5, 7th Generation
- 16 GB
- 240 GB SSD

The information applies to all the following functional requirements:

- 2 channel
- 2 s cycle
- 1000 x/y points
- 5 windows per channel
- Including data transfer of the standard data object



# TOX® Software

## Window functions

The window functions offer an integrated full-value process monitor for every piece part. There are versatile options via the freely definable and designable windows.

This provides you high process stability and early detection of errors.

### General information

The window function consists of 5 freely definable windows per channel. Every channel has an x-, y- and time track. Every window can be freely parameterized to x/y-, x/time- and y/time evaluation.

For quality assurance, 5,000 diagram points are available per track.

### Window illustration

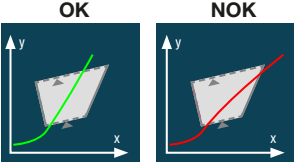
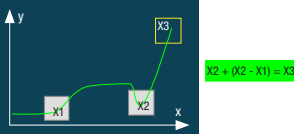
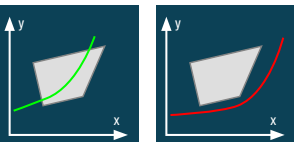
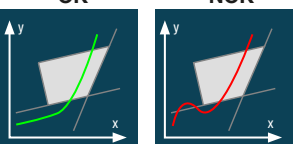
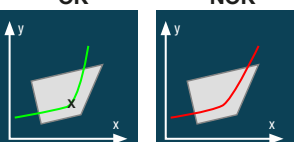
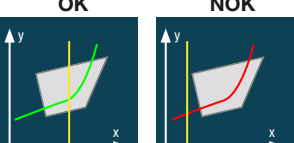
	Designation	Explanation	Application
	Entry and exit	The entry and exit sides of the window are freely definable and are monitored.	Force-displacement monitoring during the pressing of elements
	Calculation	One calculation operation is performed with two process values that can determine a new target window.	Measuring piece parts during pressing
	Must contact	The curve must contact the set window.	Force-displacement monitoring during the pressing of elements
	Extended lines	The lines specify the corridor. The force-displacement line must enter the window past the lines (saving of 2 windows).	Force-displacement monitoring during the pressing of elements
	Break point detection	The slope must reach a defined value. This is stored and is relevant for the execution of further motion.	Pressing with force at piece part fluctuations
	Digital input	A defined digital signal must be triggered in the area of the window.	Monitoring of sequential processes such as prevention of collisions

		Designation	Explanation	Application
<b>OK</b> 	<b>NOK</b> 	Integral	Calculation and evaluation of the area below the curve.	Monitoring of the energy introduced in a piece part
<b>OK</b> 	<b>NOK</b> 	Intersection within windows	The defined line (x or y) must be crossed within the window. The value is recorded.	Detecting the position of the excess of force
<b>OK</b> 	<b>NOK</b> 	Hysteresis	Evaluates the hysteresis (x or y) between an advancing or retracting curve.	Detection of a permanent deformation of a piece part
<b>OK</b> 	<b>NOK</b> 	Load drop	A target value, determined by the difference of both lines, must be reached.	Break of piece part during joining
<b>OK</b> 	<b>NOK</b> 	Time monitoring	Monitoring the time between entry and exit.	Check of time functions such as filling of liquids
<b>OK</b> 	<b>NOK</b> 	Average value	An average value is calculated and monitored within the window.	Check of the average force that is introduced in a piece part
<b>OK</b> 	<b>NOK</b> 	Peak point	A peak value must be reached within a window.	Monitoring a maximum such as a slot in a piece part
<b>OK</b> 	<b>NOK</b> 	Differential average value	Calculation of differentials between entry and exit of the window.	Evaluation of fit tightness on a piece part
<b>OK</b> 	<b>NOK</b> 	Differential of current values	The actual slope is constantly recorded and evaluated (deviation).	Evaluation of fit tightness on a piece part

# TOX® Software

## Quality data

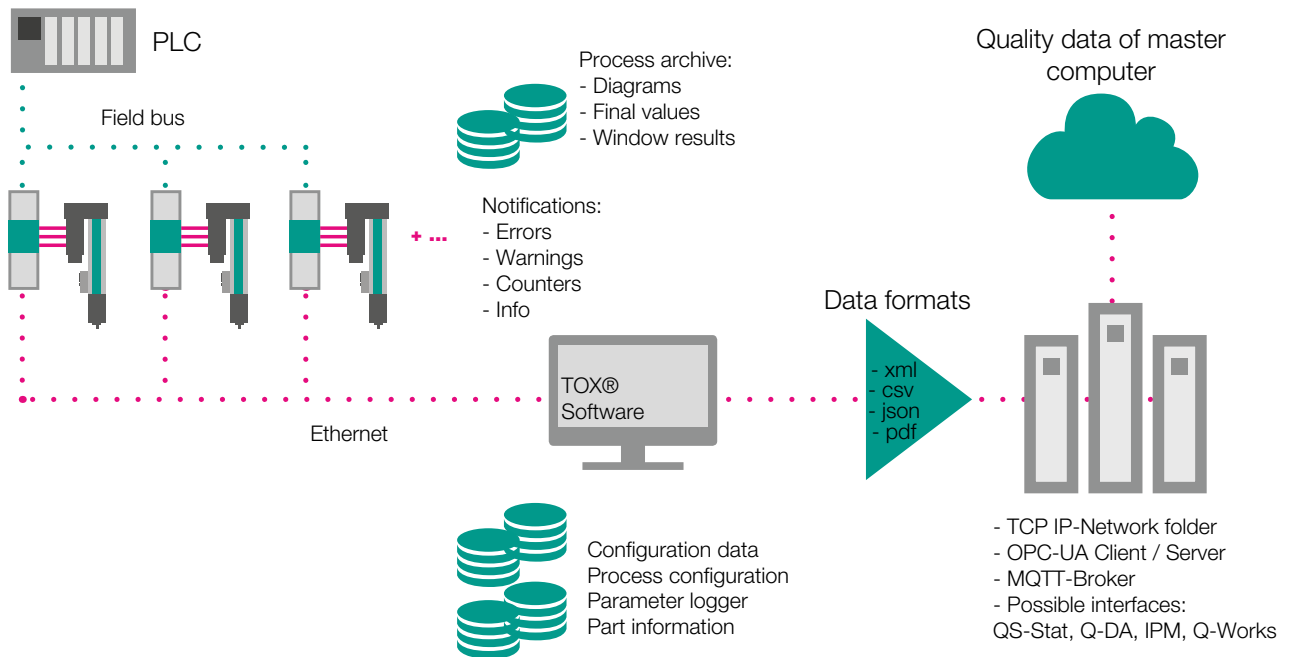

Seamless quality assurance can be carried out. We offer the most flexible integration into the database and/or to the management/production system.

5,000 diagram points are available per track. Final values, two intermediate values each with force and travel as well as minimum and maximum force/travel are recorded. The maximum and minimum

entry, exit and average of force/travel and the window results of the respective window functions are recorded.

- Different data formats, such as CSV, JSON, XML.
- Transmission protocols: TCP/IP, MQTT, FTP, OPC UA
- Data content: final value, diagram, drive data, device data, customer-specific data (i.e. part serial #)

## Multi-channel capability

The multi-channel capability is an outstanding function of the TOX® ElectricDrive Core system.

- Closed loop monitoring: i.e. monitoring of the integrated measuring technology with redundancy
- 10 tracks per channel
- 5000 diagram points for each track
- Quality assurance via switchover to external transducers and additional machine parameters
- Evaluation of all parameters within a system

# System key

The TOX® ElectricDrive Core system is available in many different versions.

The type key comprises all components of the system and its technical data, or characteristics.

The following table is used for the interpretation of key numbers and explains the number combinations.

## Breakdown of type key

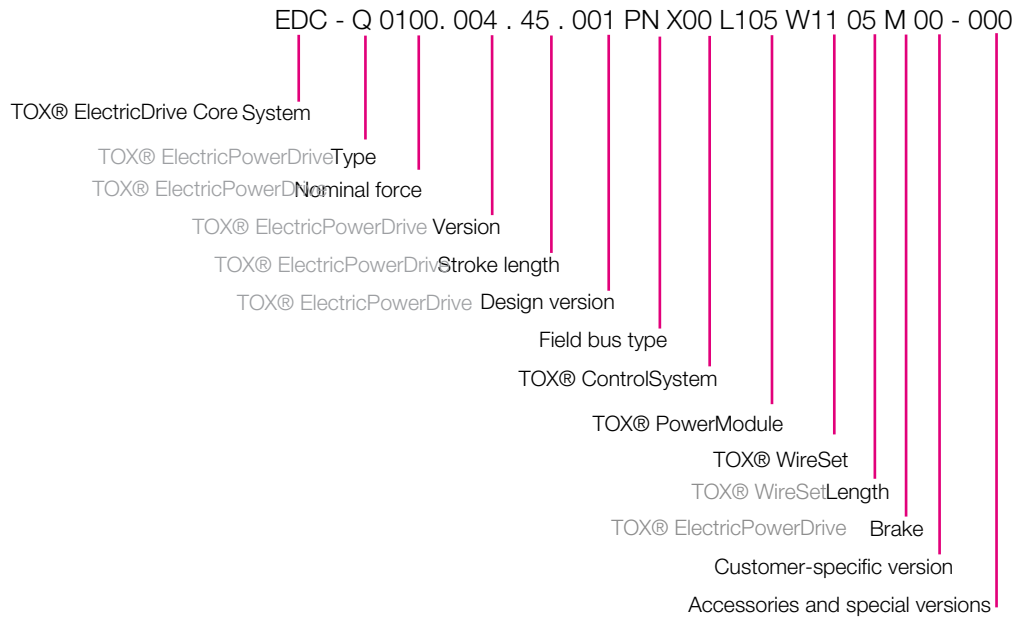

Designation	Description
System	Designates the entire system: TOX® ElectricDrive Core or TOX® ElectricDrive Advanced.
TOX® ElectricPowerDriveType	Designates the TOX® ElectricPowerDrive type, such as EQe-K, or EXe-K, EXe-F, EXe-L, or EXe-R.
Nominal force	Indicates the nominal press force.
Version	Designates the TOX® ElectricPowerDrive version, such as with external rotary encoder or motor with fan.
Stroke length	Indicates the stroke length in cm.
Design version	Indicates the TOX® ElectricPowerDrive design version.
Field bus type	Indicates the bus version used.
TOX® ControlSystem	Indicates the selection option of the PC. (only for TOX® ElectricDrive Advanced).
TOX® PowerModule Core	Indicates the selection option of the controller. (only for TOX® ElectricDrive Advanced).
TOX® WireSet	Indicates the selection option of the cable setup, e.g. halogen-free, robot/cable-track compatible.
TOX® WireSetlength	Indicates the cable length.
TOX® ElectricPowerDrive Brake	Indicates the brake type, such as motor holding brake, safety brake.
Customer-specific version	Indicates the customer-specific version.
Accessories and special versions	Indicates the special versions.